

Calibration mixtures in piston cylinders for laboratory applications

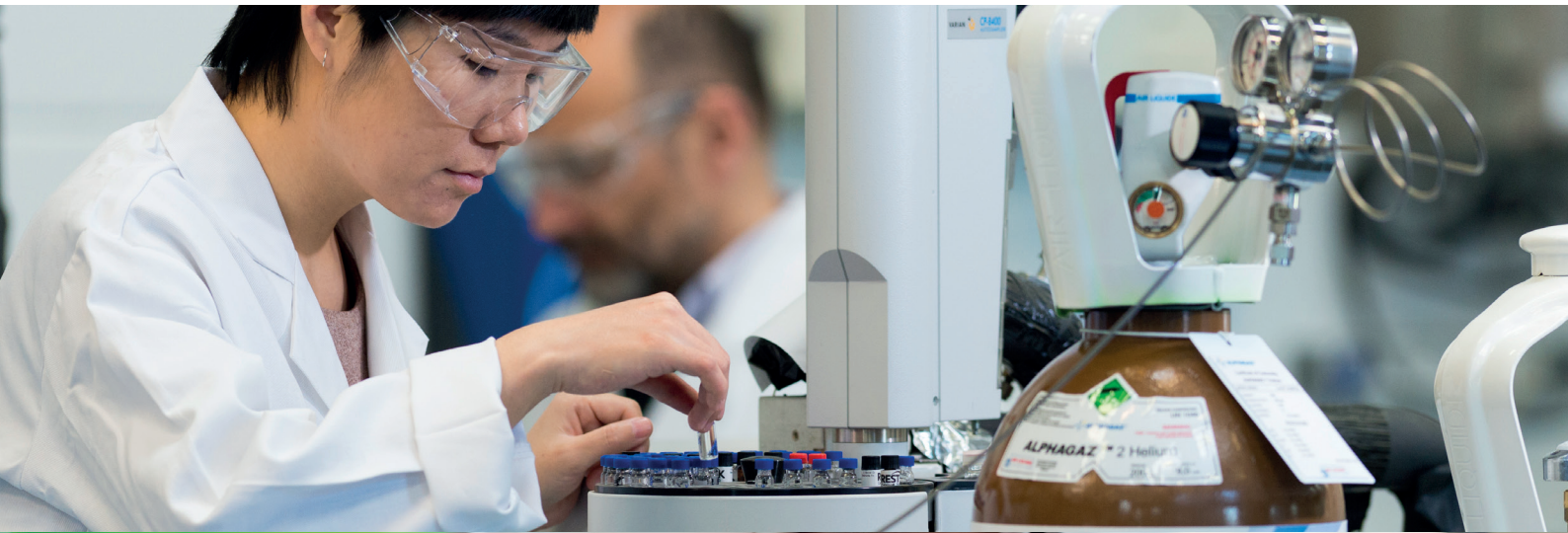

We Create Value

Air Liquide offers technical know-how and experience, together with our comprehensive offer of gas products and equipment such as the most extensive list of analysed hydrocarbon components to produce certified liquid and gaseous mixtures, brought selection of cylinders and pressure reducers that fit critical on-line and off-line calibration applications and more.

Our expertise in hydrocarbon mixtures allows us to provide liquid mixtures in floating piston cylinders and guarantee a homogeneous product throughout the cylinder consumption until the expiration date.

Your solution for accurate calibration of liquid mixtures with liquefied or vapour components

Avoid Calibration errors

Prevent incorrect calibration due to vaporization of lighter hydrocarbons observed when withdrawing liquid phase from a high pressure cylinder with dip-tube.

Achieve the highest possible consistency

Greatest consistency of liquefied hydrocarbon mixtures throughout the total contents of the cylinder.

Compliance to the industry's standards

Piston cylinders are the recommended method in several ASTM standards.

Identical sample and calibration mixture matrix

Piston cylinder allow production of calibration mixture in same component matrix as the analysed sample.

Off-line Laboratory Instrument Calibration

A potential problem with liquid hydrocarbon calibration mixtures supplied in cylinders with dip-tube and helium pressure pad is that changes in pressure or temperature may lead to phase changes within the cylinder. Vaporization of one or more lighter, high vapour pressure components will occur as liquid is withdrawn from the cylinder. When this occurs, the resulting composition is going to be different from the original composition.

Light end and heavy hydrocarbons remain completely in the liquid phase and homogeneity of the hydrocarbon mixture is ensured when supplied in Air Liquide's constant pressure piston cylinder.

You can contact your Air Liquide representative regarding your specific liquid mixture needs and to discuss the necessity and availability of computer programs to determine the phase characteristics of gas and liquid mixtures.

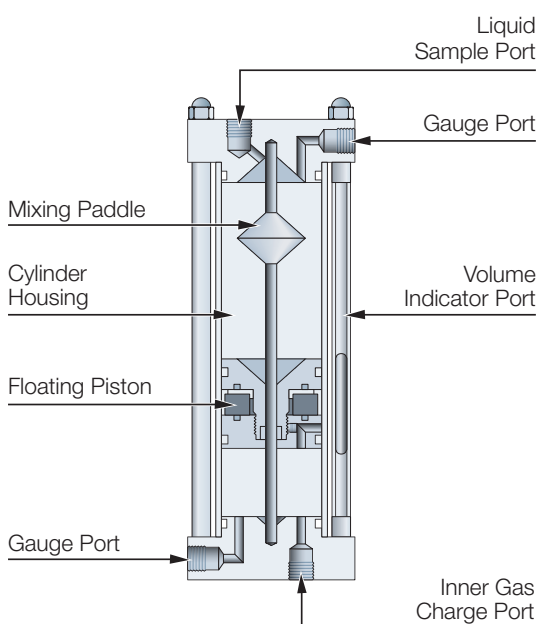

Piston cylinders

Liquid mixtures in piston cylinders are gravimetrically prepared.

The pressure within the piston is maintained by pressurizing one side of the floating piston with an inert gas such as helium.

The floating piston effectively separates the liquid from the inert gas.

Liquid is drawn off the cylinder by maintaining a constant pressure on one side of the piston using the inert gas. The constant pressure on the piston prevents the lighter components from volatilizing.

Dependable equipment with proven supply chain

Each Air Liquide piston cylinder comes standard with valves, gauges and a rupture disc relief valve with magnetic or rod-type product level indicator. Piston cylinders are shipped in protective case to withstand transport hazards and for carrying convenience



Keep it simple

- Accurate calibration solution for liquid mixtures that contain liquefied or vapour components
- Clear and concise Certificate of Analysis
- Transparency on Accuracy and Traceability of true value
- Direct access to gas experts from our Expertise Centre

Air Liquide also provides instrument validation solutions for use of liquid mixtures with liquefied or vapour components in on-line process analyser applications. Please contact your Air Liquide representative regarding your specific liquid mixture need for online applications..

Dependable equipment with proven supply chain

Piston cylinders are the recommended method in ASTM D2163-07 (Standard test method for the determination of hydrocarbons in liquefied petroleum (LP) gases and Propane/Propene mixture gases by GC.)

Air Liquide also provides hydrocarbon blends in piston cylinders for ASTM Methods 2887 and 3710.

Determination of the uniformity of composition in a liquid hydrocarbon mixture during depletion

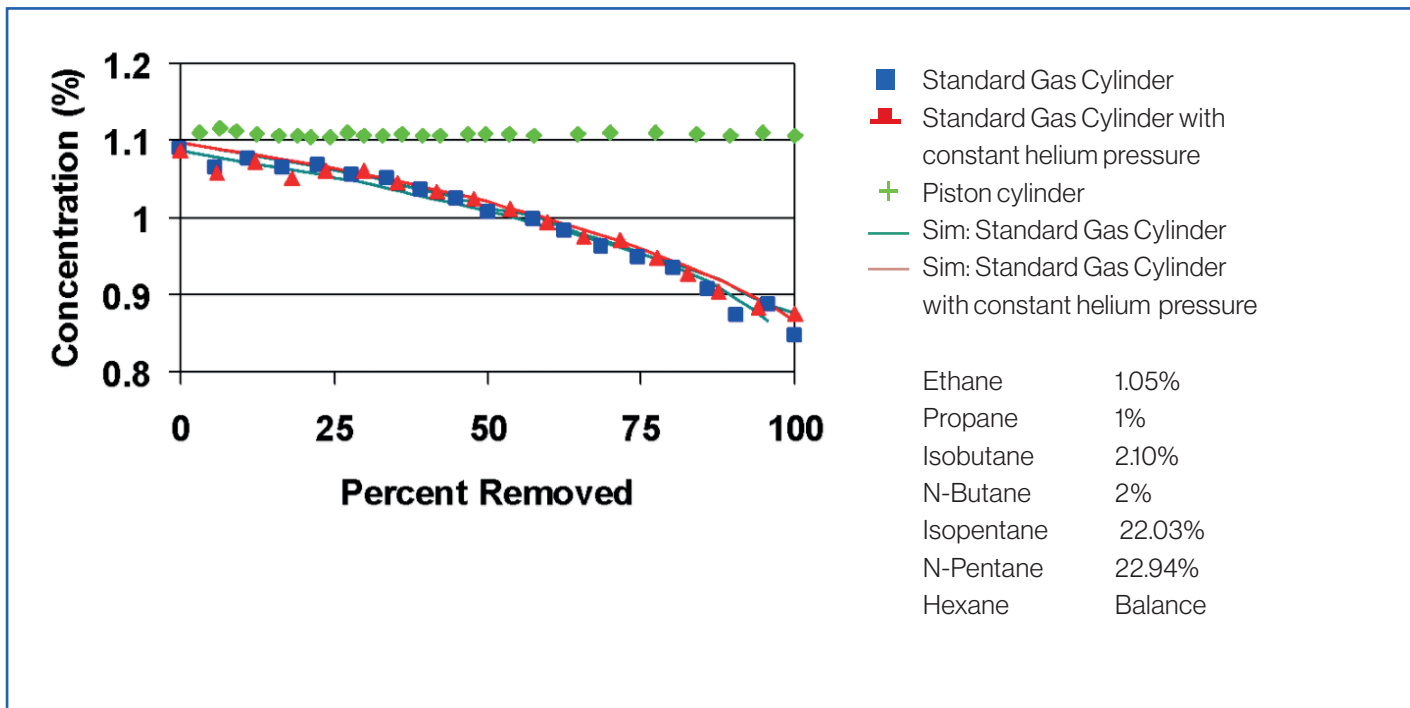

Excerpt from the 1999 paper "A Comparison of Liquid Hydrocarbon Calibration Standards in Piston Cylinders and Standard Cylinders with Educator Tubes" by Robert Benesch and Tracey Jacksier, Ph.D. Air Liquide



4 liters piston cylinder in titanium

CLU_00007_201709_R&A

- ✓ Simpler choices
- ✓ Consistent, reliable service
- ✓ Quality you can depend on

www.airliquide.com



The world leader in gases, technologies and services for Industry and Health, Air Liquide is present in 80 countries with approximately 67,000 employees and serves more than 3 million customers and patients.